

Art. No. 587208

DC 12/24 V

Preliminary Steps

1. Read all instructions carefully and study diagrams before installing lights.
2. Check with state and local authorities for laws governing usage and proper mounting of auxiliary lamps.
3. Disconnect ground connection from battery (marked "-") to avoid accidental short circuits before attempting to connect electrical wires.
4. Route new wires along existing wiring.
Tape as necessary to correct slack.
5. When running wires through the firewall, keep them away from moving parts.

Mounting Lights

1. Drill 9mm holes for screw placement on the surface where you would like to fix the light.
2. Use the bolt to fasten the lamp, add the locking washer and tighten the bolt.

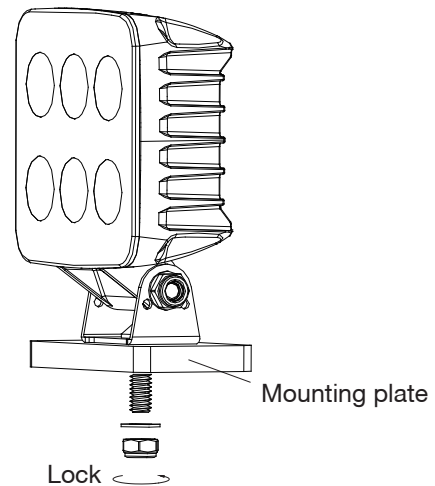

Wiring Instructions

1. Mount switch in a convenient location where it is easily reached from the driver's seat.
2. Wiring: Red "+", black "-". Attach the Red wire with annular terminal to positive side "+", and the black wire with annular terminal to negative side "-" on battery or ground. (Vehicles)
3. Make sure the working voltage (DC12V/24V), choose the corresponding relays. (DC12V/24V)
4. Insert the lamp connector (A) to wiring connector (B)
5. Turn on the switch to make sure if the lamp works. If not, please check carefully if the wiring installing correct.

Warning:

1. Work under the specified voltage (DC9-36V)
2. This light becomes hot under continuous use. Don't remove or touch the casing for at least 30 minutes after turning the lamp off.
3. Keep heat-sink clean and exposed to maintain air flow.

